

POWERED by
Loncin

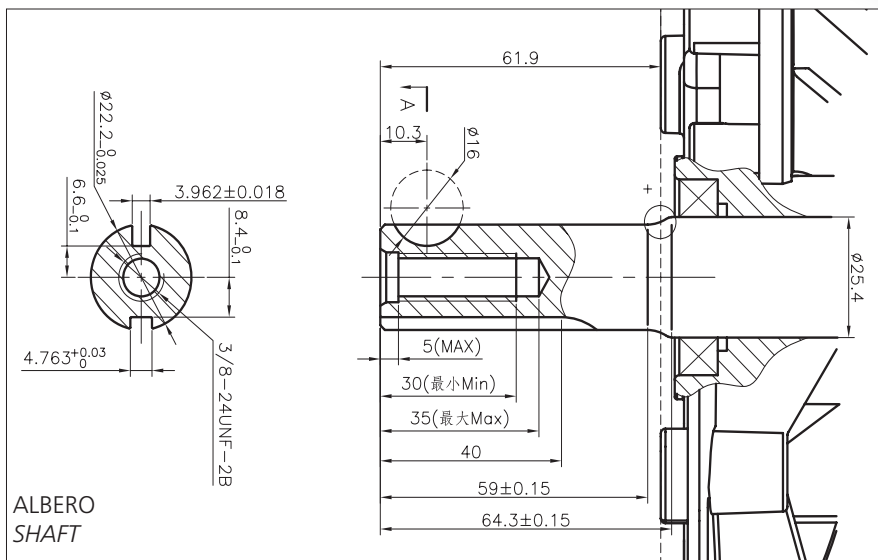

MOTORE AD ALBERO VERTICALE 4 TEMPI - VERTICAL SHAFT ENGINE 4 STROKE

Modello Model	Potenza nominale Rated power	Coppia massima Max. torque		Sistema avviamento Starting system	Cilindrata Displacement	Carburante Fuel
type	3600 r.p.m.	Nm	rpm	type	cc	type
Monocilindrico, raffreddamento ad aria, 4 - tempi Single cylinder, forced air cooling, 4 - stroke	3,6 kW	10,5	2500	manuale recoil	196	Benzina Gasoline

Capacità serbatoio Tank capacity	Capacità serbatoio olio Oil tank capacity	Rumorosità Noise	Alesaggio corsa Bore Stroke	Dimensioni Dimensions	Peso a secco Dry weight
lt	lt	≤7m dB (A)	mm	mm	Kg
1	0,6	70	70 x 51	385 x 358 x 278	13